



US010390389B2

(12) **United States Patent**  
**Jung et al.**

(10) **Patent No.:** **US 10,390,389 B2**  
(45) **Date of Patent:** **Aug. 20, 2019**

(54) **FLEXIBLE ORGANIC LIGHT-EMITTING DISPLAY APPARATUS AND METHOD OF MANUFACTURING THE SAME**

(52) **U.S. Cl.**  
CPC ..... **H05B 33/04** (2013.01); **H01L 51/5253** (2013.01); **H01L 51/5256** (2013.01); **H05B 33/10** (2013.01)

(71) Applicant: **SAMSUNG DISPLAY CO., LTD.**,  
Yongin-si, Gyeonggi-do (KR)

(58) **Field of Classification Search**  
CPC ..... H05B 33/10; H05B 33/04; H01L 51/5253; H01L 51/5256  
See application file for complete search history.

(72) Inventors: **Woo-Suk Jung**, Yongin-si (KR);  
**Soon-Ryong Park**, Yongin-si (KR);  
**Hye-Jung Park**, Yongin-si (KR);  
**Seok-Gi Baek**, Yongin-si (KR);  
**Tae-Eun Kim**, Yongin-si (KR)

(56) **References Cited**  
U.S. PATENT DOCUMENTS

(73) Assignee: **Samsung Display Co., Ltd.**, Yongin-si (KR)

7,816,676 B2 10/2010 Fourst et al.  
2005/0088088 A1 4/2005 Yamazaki  
(Continued)

(\* ) Notice: Subject to any disclaimer, the term of this patent is extended or adjusted under 35 U.S.C. 154(b) by 0 days.

FOREIGN PATENT DOCUMENTS

(21) Appl. No.: **16/140,452**

JP 2004-095413 A 3/2004  
KR 10-2007-0021535 A 2/2007  
(Continued)

(22) Filed: **Sep. 24, 2018**

OTHER PUBLICATIONS

(65) **Prior Publication Data**  
US 2019/0029085 A1 Jan. 24, 2019

Korean Office Action dated Apr. 5, 2018 for Korean Patent Application No. KR 10-2012-0078958 which cites the above-identified references numbered 1-4, and from which priority is claimed by Subject U.S. Appl. No. 15/706,333.

**Related U.S. Application Data**

*Primary Examiner* — Anne M Hines  
(74) *Attorney, Agent, or Firm* — Lewis Roca Rothgerber Christie LLP

(63) Continuation of application No. 15/706,333, filed on Sep. 15, 2017, now Pat. No. 10,085,311, which is a (Continued)

**Foreign Application Priority Data**

(57) **ABSTRACT**

Jul. 19, 2012 (KR) ..... 10-2012-0078958

In one aspect, a flexible organic light-emitting display apparatus including a substrate; a display device formed on a first surface of the substrate; a thin film encapsulation layer covering the display device; and a protection film generally surrounding the substrate, the display device, and the thin film encapsulation layer, and a method of manufacturing the flexible organic light-emitting display apparatus is provided.

(51) **Int. Cl.**  
**H05B 33/04** (2006.01)  
**H05B 33/10** (2006.01)  
**H01L 51/52** (2006.01)

**10 Claims, 6 Drawing Sheets**

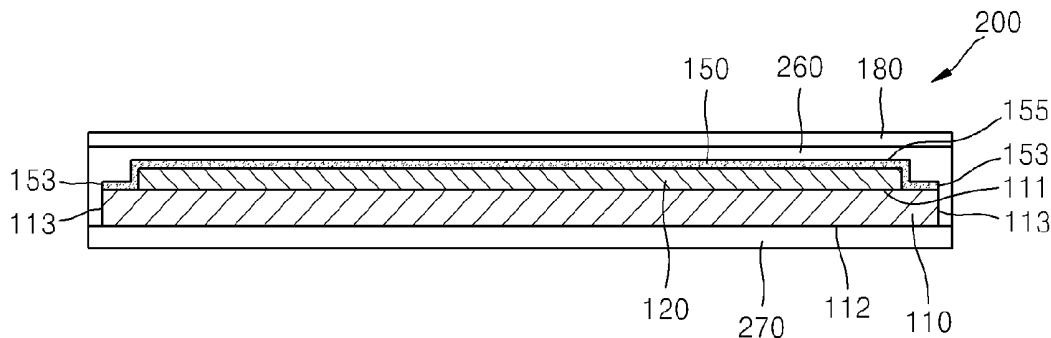

**Related U.S. Application Data**

continuation of application No. 13/687,385, filed on  
Nov. 28, 2012, now Pat. No. 9,769,886.

(56) **References Cited**

U.S. PATENT DOCUMENTS

|              |    |         |                  |
|--------------|----|---------|------------------|
| 2008/0006819 | A1 | 1/2008  | McCormick et al. |
| 2010/0327737 | A1 | 12/2010 | Hayashi et al.   |
| 2011/0171439 | A1 | 7/2011  | Jahromi et al.   |
| 2013/0241076 | A1 | 9/2013  | Mandlik et al.   |

FOREIGN PATENT DOCUMENTS

|    |                 |   |         |
|----|-----------------|---|---------|
| KR | 10-2010-0032703 | A | 3/2010  |
| KR | 10-2010-0130898 | A | 12/2010 |
| KR | 10-2011-0045820 | A | 5/2011  |
| KR | 10-2012-0062191 | A | 6/2012  |

FIG. 1

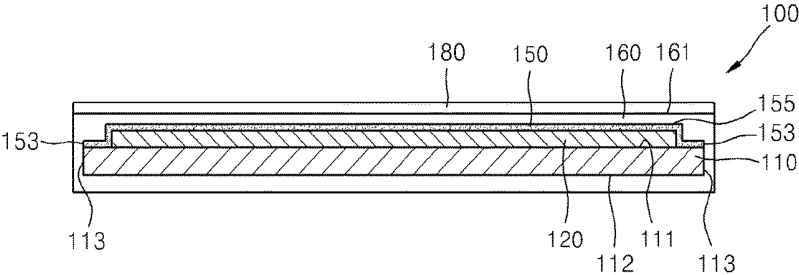

FIG. 2

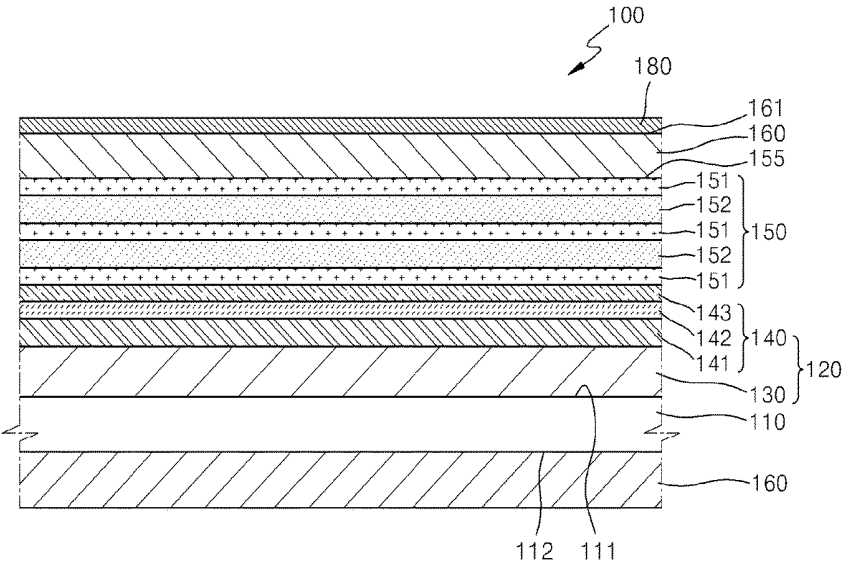

FIG. 3

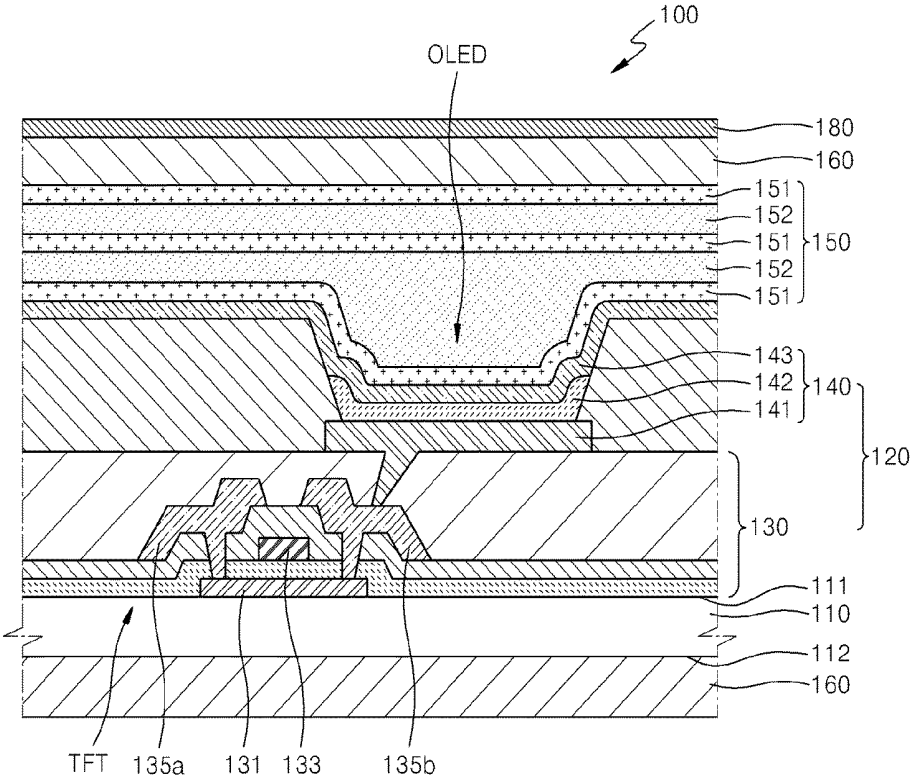

FIG. 4

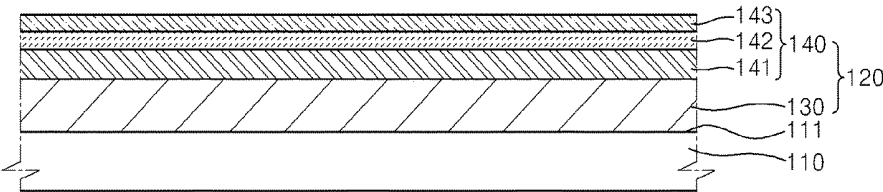

FIG. 5

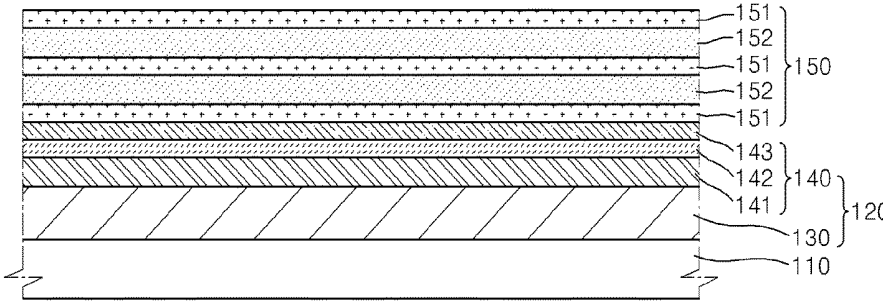

FIG. 6

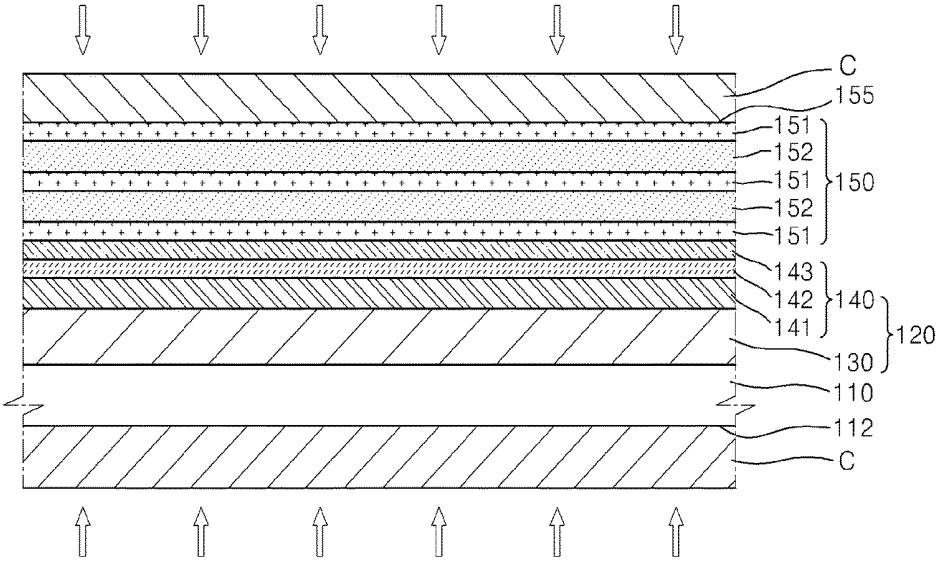

FIG. 7

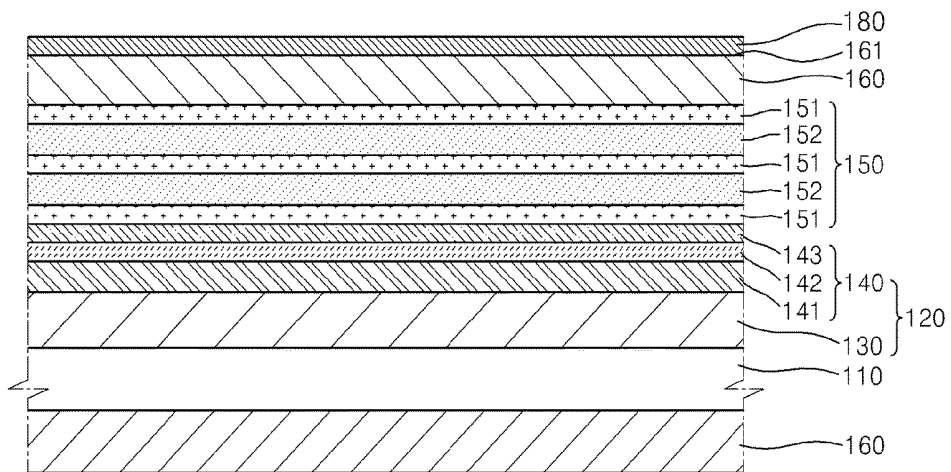

FIG. 8

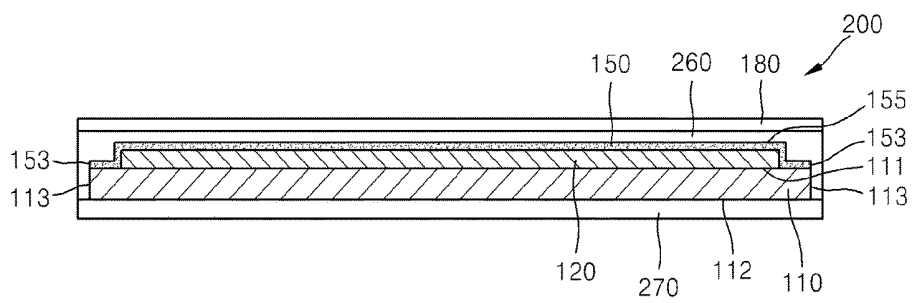
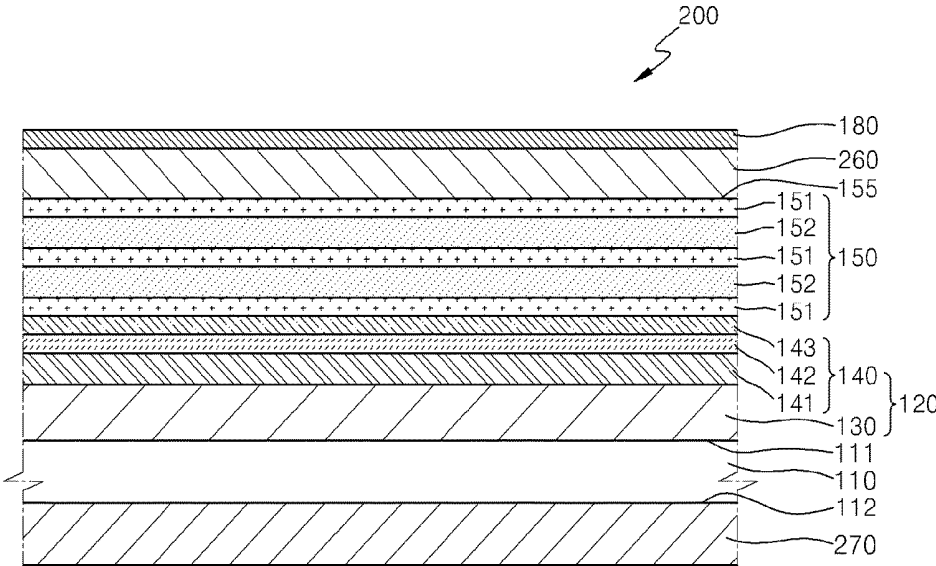

FIG. 9



## FLEXIBLE ORGANIC LIGHT-EMITTING DISPLAY APPARATUS AND METHOD OF MANUFACTURING THE SAME

### CROSS-REFERENCE TO RELATED APPLICATIONS

This application is a continuation of U.S. patent application Ser. No. 15/706,333, filed Sep. 15, 2017, which is a continuation of U.S. patent application Ser. No. 13/687,385, filed Nov. 28, 2012, now U.S. Pat. No. 9,769,886, which claims priority to and the benefit of Korean Patent Application No. 10-2012-0078958, filed Jul. 19, 2012, the entire content of all of which is incorporated herein by reference.

### BACKGROUND

#### Field

The described technology generally relates to a flexible organic light-emitting display apparatus and a method of manufacturing the same.

#### Description of the Related Technology

An organic light-emitting display apparatus typically includes an organic light-emitting diode (OLED) including a hole injection electrode, an electron injection electrode, and an organic emission layer between the hole and electron injection electrodes, and is a self-emissive display apparatus in which light is emitted while excitons generated when holes injected by the hole injection electrode and electrons injected by the electron injection electrode are combined in the organic emission layer transit from an excited state to a ground state.

As self-emissive display apparatuses, organic light-emitting display apparatuses may be driven at a low voltage and may have a small weight and thickness since an additional light source is not required, and since they may have wide viewing angles, high contrast, and fast response speeds.

However, since an organic light-emitting display apparatus may deteriorate due to external moisture or oxygen, an OLED may be sealed to protect the OLED from external moisture or oxygen.

### SUMMARY

The present embodiments provide a flexible organic light-emitting display apparatus, and a method of manufacturing the same.

Some embodiments provide a flexible organic light-emitting display apparatus including: a substrate; a display device formed on a first surface of the substrate; a thin film encapsulation layer covering the display device; and a protection film generally surrounding the substrate, the display device, and the thin film encapsulation layer.

In some embodiments, the protection film may include one or more components selected from the group consisting of a silicon (Si) material, an acryl-based resin material, and a urethane-based resin material.

In some embodiments, the silicon (Si) material may include one or more components selected from the group consisting of a silica-based material, a polysilazane-based material, and a siloxane-based material.

In some embodiments, a maximum thickness of the protection film may be 400  $\mu\text{m}$ .

In some embodiments, the protection film generally may surround a first surface of the thin film encapsulation layer, side surfaces of the thin film encapsulation layer and the substrate, and a second surface of the substrate.

5 In some embodiments, the protection film may include a first protection film that covers a first surface of the thin film encapsulation layer and side surfaces of the thin film encapsulation layer and the substrate, and a second protection film that covers a second surface of the substrate.

10 In some embodiments, the second protection film may include a flexible film.

In some embodiments, the thin film encapsulation layer may include inorganic films and organic films that are alternately stacked.

15 In some embodiments, the flexible organic light-emitting display apparatus may further include an optical film disposed on a first surface of the protection film.

20 Some embodiments provide a flexible organic light-emitting display apparatus including: a flexible substrate; a pixel electrode disposed on a first surface of the flexible substrate; a counter electrode disposed on the pixel electrode; an organic emission layer disposed between the pixel electrode and the counter electrode and emitting light; a thin film encapsulation layer disposed on the counter electrode; and a protection film generally surrounding the flexible substrate, the pixel electrode, the counter electrode, the organic emission layer, and the thin film encapsulation layer.

30 In some embodiments, the protection film may include one or more components selected from the group consisting of a silica-based material, a polysilazane-based material, a siloxane-based material, an acryl-based resin material, and a urethane-based resin material.

35 In some embodiments, the protection film may generally surround a first surface of the thin film encapsulation layer, side surfaces of the thin film encapsulation layer and the flexible substrate, and a second surface of the flexible substrate.

40 In some embodiments, the protection film may include a first protection film that covers a first surface of the thin film encapsulation layer and side surfaces of the thin film encapsulation layer and the flexible substrate, and a second protection film that covers a second surface of the flexible substrate and includes a material different from the first protection film.

45 Some embodiments provide a method of manufacturing a flexible organic light-emitting display apparatus, the method including: forming a display device on a first surface of a substrate; forming a thin film encapsulation layer covering the display device; and forming a protection film that generally surrounds the substrate, the display device, and the thin film encapsulation layer.

50 In some embodiments, the forming of the protection film may include: forming a coating layer to generally surround the substrate, the display device, and the thin film encapsulation layer, wherein the coating layer includes a protection film forming curing material; and curing the coating layer at a temperature below 200° C. and forming the protection film.

55 In some embodiments, the protection film forming curing material may include one or more components selected from the group consisting of a silica-based material, a polysilazane-based material, a siloxane-based material, an acryl-based resin material, and a urethane-based resin material.

60 In some embodiments, the forming of the thin film encapsulation layer may include: forming inorganic films; and forming organic films.

In some embodiments, the forming of the protection film may include: forming a coating layer to generally surround a first surface and side surfaces of a stack structure of the substrate, the display device, and the thin film encapsulation layer, wherein the coating layer includes a protection film forming curing material; curing the coating layer at a temperature below 200° C. and forming a first protection film; and attaching a flexible film to cover a second surface of the stack structure and forming a second protection film.

In some embodiments, the method may further include: forming an optical film directly on the protection film.

#### BRIEF DESCRIPTION OF THE DRAWINGS

The above and other features and advantages of the present embodiments will become more apparent by describing in detail exemplary embodiments thereof with reference to the attached drawings in which:

FIG. 1 is a schematic cross-sectional view of a flexible organic light-emitting display apparatus according to an aspect of the present embodiments;

FIG. 2 is a detailed cross-sectional view of the flexible organic light-emitting display apparatus of FIG. 1;

FIG. 3 is a schematic cross-sectional view of one pixel region of the flexible organic light-emitting display apparatus of FIG. 2;

FIGS. 4 through 7 are sequential cross-sectional views for describing a method of manufacturing the flexible organic light-emitting display apparatus of FIG. 1, according to an aspect of the present embodiments;

FIG. 8 is a schematic cross-sectional view of a flexible organic light-emitting display apparatus according to an aspect of the present embodiments; and

FIG. 9 is a detailed cross-sectional view of the flexible organic light-emitting display apparatus of FIG. 8.

#### DETAILED DESCRIPTION

Hereinafter, the present disclosure will be described in detail by explaining exemplary embodiments with reference to the attached drawings. The invention may, however, be embodied in many different forms and should not be construed as being limited to the embodiments set forth herein. Meanwhile, the terminology used herein is for the purpose of describing particular embodiments and is not intended to limit the invention. As used herein, the singular forms are intended to include the plural forms as well, unless the context clearly indicates otherwise. It will be further understood that the terms “comprises” and/or “comprising,” when used in this specification, specify the presence of stated features, integers, steps, operations, elements, and/or components, but do not preclude the presence or addition of one or more other features, integers, steps, operations, elements, components, and/or groups thereof. Also, it will be understood that, although the terms ‘first’, ‘second’, etc. may be used herein to describe various elements, these elements should not be limited by these terms. These terms are only used to distinguish one element from another.

In the drawings, lengths and sizes of layers and regions may be exaggerated for clarity. It will be understood that when an element or layer is referred to as being “on” another element or layer, the element or layer can be directly on another element or layer or intervening elements or layers. In contrast, when an element is referred to as being “directly on” another element or layer, there are no intervening elements or layers present.

As used herein, the term “and/or” includes any and all combinations of one or more of the associated listed items. Expressions such as “at least one of,” when preceding a list of elements, modify the entire list of elements and do not modify the individual elements of the list.

As used herein, the term “generally surrounds” or “generally surrounding” refers an item covering all exposed surfaces of the listed items. For example, embodiments that state a protection film generally surrounds a substrate, a display device, and a thin film encapsulation layer provides that the protection film covers all the exposed surfaces of the substrate, the display device, and the thin film encapsulation layer.

FIG. 1 is a schematic cross-sectional view of a flexible organic light-emitting display apparatus 100 according to an embodiment. FIG. 2 is a detailed cross-sectional view of the flexible organic light-emitting display apparatus 100 of FIG. 1. FIG. 3 is a schematic cross-sectional view of one pixel region of the flexible organic light-emitting display apparatus 100 of FIG. 2.

Referring to FIGS. 1 and 2, the flexible organic light-emitting display apparatus 100 (hereinafter referred to as an “organic light-emitting display apparatus”) according to an embodiment of the present invention may include a substrate 110, a display device 120 disposed on a first surface 111 of the substrate 110, a thin film encapsulation layer 150 disposed on the display device 120, and a protection film 160. The protection film 160 may be formed to generally surround the substrate 110, the display device 120, and the thin film encapsulation layer 150.

Referring to FIGS. 2 and 3, the display device 120 may include an organic light-emitting diode (OLED) 140 including a pixel electrode 141 disposed on the substrate 110, a counter electrode 143 disposed on the pixel electrode 141, and an organic emission layer 142 disposed between the pixel electrode 141 and the counter electrode 143. In some embodiments, the OLED 140 emits red, green, and blue light according to current and displays predetermined image information. In some embodiments, the OLED 140 may be disposed on a device/wiring layer 130.

In some embodiments, the substrate 110 may be a flexible substrate and may include polymer having excellent heat resistance and durability. For example, the substrate 110 may include any one selected from the group consisting of polyethersulfone (PES), polyarylate (PAR), polyetherimide (PEI), polyethylene naphthalate (PEN), polyethylene terephthalate (PET), polyphenylene sulfide (PPS), polyallylate, polyimide (PI), polycarbonate (PC), cellulose triacetate, cellulose acetate propionate (CAP), poly(arylene ether sulfone), and a combination thereof.

In some embodiments, the device/wiring layer 130 may be disposed on the first surface 111 of the substrate 110 and may include a driving thin film transistor (TFT) for driving the OLED 140, a switching thin film transistor (not shown), a capacitor, and wirings (not shown) connected to the driving TFT and the capacitor. The driving TFT includes an active layer 131, a gate electrode 133, and source and drain electrodes 135a and 135b.

Although not shown, a barrier layer for preventing penetration of external impurities such as moisture or oxygen into the OLED 140 through the substrate 110 may be further disposed between the substrate 110 and the device/wiring layer 130.

The OLED 140 is disposed on the device/wiring layer 130. The OLED 140 includes the pixel electrode 141, the

organic emission layer **142** disposed on the pixel electrode **141**, and the counter electrode **143** formed on the organic emission layer **142**.

In some embodiments, the pixel electrode **141** may be an anode and the counter electrode **143** may be a cathode. However, the present embodiments are not limited thereto and, according to a driving method of the organic light-emitting display apparatus **100**, the pixel electrode **141** may be a cathode and the counter electrode **143** may be an anode. Holes and electrons are injected from the pixel electrode **141** and the counter electrode **143**, respectively, into the organic emission layer **142**. Light is emitted while excitons formed when the injected holes and electrons are combined transit from an excited state to a ground state.

The pixel electrode **141** is electrically connected to the driving TFT of the device/wiring layer **130**.

Although the OLED **140** is disposed on the device/wiring layer **130** including the driving TFT in the present embodiment, the present invention is not limited thereto and various modifications may be made. For example, the pixel electrode **141** of the OLED **140** may be formed at the same level as the active layer **131**, the gate electrode **133**, or the source and drain electrodes **135a** and **135b** of the driving TFT.

Furthermore, although the gate electrode **133** of the driving TFT is depicted as disposed above the active layer **131** the present embodiments is not limited thereto and the gate electrode **133** may also be disposed under the active layer **131**.

In some embodiments, the pixel electrode **141** of the OLED **140** may be a reflective electrode and may include a reflective film formed of silver (Ag), magnesium (Mg), aluminum (Al), platinum (Pt), palladium (Pd), gold (Au), nickel (Ni), neodymium (Nd), iridium (Ir), chromium (Cr), or a compound thereof, and a transparent or translucent electrode layer formed on the reflective film.

In some embodiments, the transparent or translucent electrode layer may include at least one selected from the group consisting of indium tin oxide (ITO), indium zinc oxide (IZO), zinc oxide (ZnO), indium oxide (In<sub>2</sub>O<sub>3</sub>), indium gallium oxide (IGO), and aluminum zinc oxide (AZO).

In some embodiments, the counter electrode **143** disposed to face the pixel electrode **141** may be a transparent or translucent electrode, and may be formed as a metallic thin film including lithium (Li), calcium (Ca), lithium fluoride/calcium (LiF/Ca), lithium fluoride/aluminum (LiF/Al), aluminum (Al), silver (Ag), magnesium (Mg), or a compound thereof, and having a low work function. Also, an auxiliary electrode layer or a bus electrode may be further formed on the metallic thin film by using a material for forming a transparent electrode, e.g., ITO, IZO, ZnO, or In<sub>2</sub>O<sub>3</sub>.

Accordingly, the counter electrode **143** may transmit the light emitted from the organic emission layer **142**.

Although the depicted embodiments describe a case where light emitted from the OLED **140** is emitted toward a top surface, i.e., the first surface **111** of the substrate **110** (a top emission type), the present embodiments are not limited thereto. In some embodiments, the light may be emitted toward a second surface **112** of the substrate **110** (a bottom emission type), and the light may be emitted toward the first and second surfaces **111** and **112** of the substrate **110** (a dual emission type). In the case where the organic light-emitting display apparatus **100** according to an embodiment of the present invention is a bottom emission type display apparatus, the pixel electrode **141** may be formed as a semi-transmission film, and the counter electrode **143** may be formed as a reflective film. In some

embodiments, where the organic light-emitting display apparatus **100** is a dual emission type display apparatus, the pixel electrode **141** and the counter electrode **143** may be formed as transparent or translucent films.

In some embodiments, the organic emission layer **142** may be disposed between the pixel electrode **141** and the counter electrode **143**, and may be formed of a low-molecular or high-molecular organic material.

In addition to the organic emission layer **142**, intermediate layers such as a hole transport layer (HTL), a hole injection layer (HIL), an electron transport layer (ETL), and an electron injection layer (EIL) may be selectively disposed between the pixel electrode **141** and the counter electrode **143**.

In some embodiments, the thin film encapsulation layer **150** may seal and protect the OLED **140** from the outside. In some embodiments, the thin film encapsulation layer **150** may include a thin film including one or more inorganic films **151** and one or more organic films **152**. In some embodiments, the substrate **110** may be the flexible substrate, and the thin film encapsulation layer **150** may be formed as the thin film including the inorganic films **151** and the organic films **152**, thereby easily implementing flexibility and thinning of the organic light-emitting display apparatus **100**.

In some embodiments, the inorganic films **151** may be disposed closest to the OLED **140** and include a metal oxide, a metal nitride, a metal carbide, or a compound thereof. For example, the inorganic films **151** may include at least one inorganic material from Al<sub>2</sub>O<sub>3</sub>, TiO<sub>2</sub>, ZrO, SiO<sub>2</sub>, AlON, AlN, SiON, Si<sub>3</sub>N<sub>4</sub>, ZnO, and Ta<sub>2</sub>O<sub>5</sub>.

In some embodiments, the organic films **152** may include polymer based materials. In some embodiments, the polymer based materials may include acryl based resin, epoxy based resin, polyimide, polyethylene, etc. In some embodiments, the organic films **152** may reduce internal stress of, complement defects of, and planarize the inorganic films **151**.

Although the depicted embodiments exemplify a case where the inorganic films **151** are stacked three times, and the organic films **152** are stacked two times, the present embodiments are not limited thereto. That is, the number of inorganic films **151** and organic films **152** that are alternately stacked is not limited by the depicted embodiments.

In some embodiments, the protection film **160** may be formed to generally surround the substrate **110**, the display device **120**, and the thin film encapsulation layer **150** while covering a first surface **155** of the thin film encapsulation layer **150**, side surfaces **113** and **153** of the thin film encapsulation layer **150** and the substrate **110**, and the second surface **112** of the substrate **110**. In some embodiments, the protection film **160** may be formed to generally surround the substrate **110**, the display device **120**, and the thin film encapsulation layer **150**, thereby preventing a thin film encapsulation from being separated from the organic light-emitting display apparatus **100** during a process of manufacturing the organic light-emitting display apparatus **100**.

A comparative example of the present embodiments, where the protection film **160** is not formed in the organic light-emitting display apparatus **100**, after the thin film encapsulation layer **150** is formed, a film may be temporarily attached so as to prevent the thin film encapsulation layer **150** from being damaged during a process of attaching an optical film **180** on the thin film encapsulation layer **150**. The temporarily attached film is removed before the optical film **180** is attached to the thin film encapsulation layer **150**. In

this regard, an adhesive force of the temporarily attached film may cause a peel-off phenomenon in that the thin film encapsulation layer 150 that is thin peels off from the substrate 110 and/or the display device 120 or a fine crack therebetween. In the case where the thin film encapsulation layer 150 peels off from the substrate 110 and/or the display device 120 or the fine crack therebetween, moisture or oxygen may penetrate into the organic emission layer 142. Also, an electrostatic force that occurs when the temporarily attached film is removed may deteriorate or damage a characteristic of the display device 120.

In contrast, according to the present embodiments, the protection film 160 may be formed to generally surround the substrate 110, the display device 120, and the thin film encapsulation layer 150, and thus no film is temporarily attached in order to protect the thin film encapsulation layer 150 during the process of manufacturing the organic light-emitting display apparatus 100.

In addition, the protection film 160 may be formed to generally surround the substrate 110, the display device 120, and the thin film encapsulation layer 150, and thus a path via which oxygen or moisture may penetrate may be totally blocked.

In some embodiments, the protection film 160 may be formed using a coating and curing method. In some embodiments, the protection film 160 may include one of a silicon (Si) material, an acryl-based resin material, and a urethane-based resin material. In some embodiments, the silicon (Si) material may include a silica-based material, a polysilazane-based material, and a siloxane-based material.

In some embodiments, the thickness of the protection film 160 may be formed to the extent that the flexibility of the organic light-emitting display apparatus 100 is not damaged. For example, the thickness of the protection film 160 may be less than about 400  $\mu\text{m}$  such that flexibility of the organic light-emitting display apparatus 100 may be secured.

In some embodiments, the optical film 180 may be further formed on a first surface 161 of the protection film 160. In some embodiments, the optical film 180 may use a phase delay plate and/or a polarization plate. In some embodiments, the optical film 180 may inhibit reflection of external light to enhance visibility and contrast of the organic light-emitting display apparatus 100.

A method of manufacturing the organic light-emitting display apparatus 100 will now be described.

FIGS. 4 through 7 are sequential cross-sectional views for describing a method of manufacturing the organic light-emitting display apparatus 100 of FIG. 1, according to an embodiment.

Referring to FIG. 4, the display device 120, including the device/wiring layer 130 and the OLED 400, including the pixel electrode 141, the organic emission layer 142, and the counter electrode 143, are formed on the first surface 111 of the substrate 110.

In some embodiments, the substrate 110 may be a flexible substrate and may be a plastic substrate including polymer having excellent heat resistance and durability as described above. In some embodiments, the flexible substrate may be disposed on a support substrate (not shown) formed of glass for supporting the flexible substrate. In some embodiments, the support substrate (not shown) may be removed after a process completely ends or during the process.

In some embodiments, a barrier layer (not shown) may be further formed on the first surface 111 of the substrate 110. In some embodiments, the barrier layer (not shown) may include the inorganic films 151 and/or the organic films 152,

and prevents penetration of external impurities into the device/wiring layer 130 and the OLED 140 through the substrate 110.

In some embodiments, the device/wiring layer 130 may include the driving TFT (see FIG. 3) for driving the OLED 140, a capacitor (not shown), and wiring (not shown).

In some embodiments, the pixel electrode 141, the organic emission layer 142, and the counter electrode 143 are sequentially formed on the device/wiring layer 130.

In some embodiments, the pixel electrode 141 may be a reflective electrode, and the counter electrode 143 may be a transparent or translucent electrode. Accordingly, light generated by the organic emission layer 142 may be emitted toward the counter electrode 143 directly or after being reflected on the pixel electrode 141. In this regard, the counter electrode 143 may be formed as a translucent electrode and thus the pixel electrode 141 and the counter electrode 143 may form a resonance structure.

In some embodiments, the organic light-emitting display apparatus 100 may be formed having a top emission type structure as described above. According to another embodiment, the organic light-emitting display apparatus 100 may be formed as a bottom emission type or a dual emission type structure. In this case, the pixel electrode 141 and the counter electrode 143 are the same as described above.

In some embodiments, the organic emission layer 142 may be formed of a low-molecular or high-molecular organic material. In addition to the organic emission layer 142, the intermediate layers as stated above may be selectively formed between the pixel electrode 141 and the counter electrode 143. Although the OLED 140 is formed on the device/wiring layer 130 in the depicted embodiment, the present embodiments are not limited thereto and the device/wiring layer 130 and the OLED 140 may be formed at the same level.

Referring to FIG. 5, the thin film encapsulation layer 150 is formed. In some embodiments, the thin film encapsulation layer 150 may be formed by alternately forming the inorganic films 151 and the organic films 152. In some embodiments, the inorganic films 151 may be formed as the lowermost and uppermost layers of the thin film encapsulation layer 150 contacting the counter electrode 143. In some embodiments, the number of inorganic films 151 and organic films 152 that are alternately formed is not limited to the number shown in FIG. 5.

Thereafter, referring to FIG. 6, a protection film forming curing material C is applied to generally surround the substrate 110, the display device 120, and the thin film encapsulation layer 150. More specifically, the protection film forming curing material C may be coated to cover the first surface 155 of the thin film encapsulation layer 150, the side surfaces 113 and 153 of the thin film encapsulation layer 150 and the substrate 110, and the second surface 112 of the substrate 110. In this regard, the protection film forming curing material C may be coated having a thickness of less than about 400  $\mu\text{m}$ . In some embodiments, the protection film forming curing material C may be coated having a thickness of less than 400  $\mu\text{m}$ . In some embodiments, the protection film forming curing material C may be coated having a thickness in a range of from 100  $\mu\text{m}$  to 400  $\mu\text{m}$ .

In some embodiments, the protection film forming curing material C may include one of a silicon (Si) material, an acryl-based resin material, and a urethane-based resin material. In some embodiments, the silicon (Si) material may include a silica-based material, a polysilazane-based material, and a siloxane-based material. In some embodiments, the protection film forming curing material C may be coated

using a spray coating method, a spin coating method, a slit coating method, etc. In some embodiments, a roller coating method may be used to coat the protection film forming curing material C.

Referring to FIG. 7, the protection film 160 may be formed by curing the protection film forming curing material C by using thermal energy or light energy such as UV light. A curing temperature may be below about 200° C. In some embodiments, a curing temperature may be below 200° C. In some embodiments, a curing temperature may be in a range of from 100° C. to 200° C. If the curing temperature exceeds 200° C., an organic light-emitting material of the organic emission layer 142 may deteriorate due to a high temperature.

In some embodiments, the protection film forming curing material C may further include an additive so that the protection film forming curing material C may be cured at the temperature below about 200° C. The additive may include palladium, an amine-based material, etc. but is not limited thereto.

In some embodiments, the optical film 180 may be further attached to the first surface 161 of the protection film 160. A process of removing impurities that are likely to be present in the first surface 161 of the protection film 160 may be further performed before the optical film 180 is attached. In some embodiments, the optical film 180 may use a phase delay plate or a polarization plate.

In the case of the organic light-emitting display apparatus according to the comparison example as described above, a film is temporarily attached so as to prevent the thin film encapsulation layer 150 from being damaged during a process of attaching the optical film 180 onto the thin film encapsulation layer 150, whereas, according to the present embodiments, the protection film 160 may be formed to generally surround the substrate 110, the display device 120, and the thin film encapsulation layer 150, and thus no film is temporarily attached in order to protect the thin film encapsulation layer 150 during the process of manufacturing the organic light-emitting display apparatus 100 as described above. In addition, the protection film 160 may be formed to generally surround the substrate 110, the display device 120, and the thin film encapsulation layer 150, and thus a path via which oxygen or moisture may penetrate may be totally blocked.

FIG. 8 is a schematic cross-sectional view of a flexible organic light-emitting display apparatus 200 according to another depicted embodiment of the present embodiments. FIG. 9 is a detailed cross-sectional view of the flexible organic light-emitting display apparatus 200 of FIG. 8.

Referring to FIGS. 8 and 9, the flexible organic light-emitting display apparatus 200 may include the substrate 110, the display device 120 disposed on the first surface 111 of the substrate 110, the thin film encapsulation layer 150 disposed on the display device 120, and protection films 260 and 270. In some embodiments, the protection films 260 and 270 may be formed to generally surround the substrate 110, the display device 120, and the thin film encapsulation layer 150. In some embodiments, the optical film 180 may be further disposed on the protection films 260 and 270, for example, directly on the protection films 260 and 270.

In some embodiments, the display device 120 may include the OLED 140 including the pixel electrode 141 disposed on the substrate 110, the counter electrode 143 disposed on the pixel electrode 141, and the organic emission layer 142 disposed between the pixel electrode 141 and the counter electrode 143. In some embodiments, the OLED 140 emits red, green, and blue light according to current and

displays predetermined image information, and may be disposed on the device/wiring layer 130, which is the same as described with reference to FIGS. 1 through 7.

However, the organic light-emitting display apparatus 100 and the flexible organic light-emitting display apparatus 200 differ from each other in that the protection film 160 described with reference to FIGS. 1 through 7 has a structure in which one material surrounds the substrate 110, the display device 120, and the thin film encapsulation layer 150, whereas the protection films 260 and 270 according to the embodiment depicted in FIGS. 8 and 9 may include two different materials.

Differences between the organic light-emitting display apparatus 100 and the flexible organic light-emitting display apparatus 200 will now be described.

The protection films 260 and 270 may surround the substrate 110, the display device 120, and the thin film encapsulation layer 150 and include the first protection film 260 formed to cover the first surface 155 of the thin film encapsulation layer 150 and the side surfaces 113 and 153 of the thin film encapsulation layer 150 and the substrate 110, and the second protection film 270 formed to cover the second surface 112 of the substrate 110.

The first protection film 260 may be formed of the same material as the protection film 160 described with reference to FIG. 1. For example, the first protection film 260 may include one or more components selected from the group consisting of a silicon (Si) material such as a silica-based material, a polysilazane-based material, or a siloxane-based material, an acryl-based resin material, and a urethane-based resin material.

As described above, the first protection film 260 may be formed by applying the protection film forming curing material C using a spray coating method and curing the protection film forming curing material C at a temperature below about 200° C. by using thermal energy or light energy such as UV light. In some embodiments, a curing temperature may be below 200° C. In some embodiments, a curing temperature may be in a range of from 100° C. to 200° C. In some embodiments, the protection film forming curing material C for forming the first protection film 260 may be applied on the first surface 155 of the thin film encapsulation layer 150 and the side surfaces 113 and 153 of the thin film encapsulation layer 150 and the substrate 110, respectively.

In some embodiments, the second protection film 270 may include a flexible film. In some embodiments, the flexible film may be attached onto the second surface 112 of the substrate 110 that is externally exposed after the first protection film 260 is formed by curing the protection film forming curing material C.

With respect to the protection films 260 and 270, the flexible organic light-emitting display apparatus 200 may include, in some embodiments, the first protection film 260, a temporary film is not used when the optical film 180 is attached, thereby preventing the thin film encapsulation layer 150 from being peeled off or a fine crack from occurring between the thin film encapsulation layer 150 and the substrate 110, and preventing a device from deteriorating or being damaged due to static electricity.

In some embodiments, an organic light-emitting material may be protected from oxygen or moisture, a manufacturing process may be simplified, and an additional film may not be temporarily attached during the manufacturing process, thereby preventing a device from deteriorating or being damaged due to the temporarily attached film.

While the present embodiments have been particularly shown and described with reference to exemplary embodi-

## 11

ments thereof, it will be understood by those of ordinary skill in the art that various changes in form and details may be made therein without departing from the spirit and scope of the embodiments defined by the following claims.

What is claimed is:

1. A flexible organic light-emitting display apparatus comprising:

- a first protection film;
- a flexible substrate on the first protection film;
- a pixel electrode on the flexible substrate;
- an organic emission layer on the pixel electrode;
- a counter electrode on the organic emission layer;
- a thin film encapsulation layer disposed on the counter electrode and including at least an organic film and at least an inorganic film, an end portion of the thin film encapsulation layer extends beyond an end of the counter electrode and partially covers an area of the flexible substrate on which the counter electrode is not disposed;
- a second protection film on the thin film encapsulation layer and covering the thin film encapsulation layer; and
- an optical film on the second protection film.

2. The display apparatus of claim 1, wherein the optical film comprises at least one of a polarization plate or a phase delay film.

3. The display apparatus of claim 1, wherein the first protection film comprises a flexible film.

4. The display apparatus of claim 1, wherein the flexible substrate comprises one or more compounds selected from the group consisting of polyethersulfone (PES), polyarylate (PAR), polyetherimide (PEI), polyethylene naphthalate (PEN), polyethylene terephthalate (PET), polyphenylene sulfide (PPS), polyimide (PI), polycarbonate (PC), cellulose triacetate, cellulose acetate propionate (CAP), and poly(arylene ether sulfone).

5. The display apparatus of claim 1, wherein the second protection film comprises one or more compounds selected from the group consisting of a silicon (Si) material, an acryl-based resin material, and an urethane-based resin material.

6. A flexible organic light-emitting display apparatus comprising:

## 12

a flexible substrate including a first surface and a second surface opposite to the first surface;

a first protection film on the first surface of the flexible substrate;

5 a pixel electrode on the second surface of the flexible substrate;

an organic emission layer on the pixel electrode;

a counter electrode on the organic emission layer;

10 a thin film encapsulation layer on the counter electrode and including at least an organic film and at least an inorganic film, wherein an end portion of the thin film encapsulation layer extends beyond an end of the counter electrode and partially covers an area of the flexible substrate on which the counter electrode is not disposed;

a second protection film on the thin film encapsulation layer and covering the thin film encapsulation layer, wherein an end portion of the second protection film extends beyond an end of the thin film encapsulation layer and partially covers an area of the flexible substrate on which the thin film encapsulation layer is not disposed; and

an optical film on the second protection film.

7. The display apparatus of claim 6, wherein the optical film comprises at least one of a polarization plate or a phase delay film.

8. The display apparatus of claim 6, wherein the first protection film comprises a flexible film.

9. The display apparatus of claim 6, wherein the flexible substrate comprises one or more compounds selected from the group consisting of polyethersulfone (PES), polyarylate (PAR), polyetherimide (PEI), polyethylene naphthalate (PEN), polyethylene terephthalate (PET), polyphenylene sulfide (PPS), polyimide (PI), polycarbonate (PC), cellulose triacetate, cellulose acetate propionate (CAP), and poly(arylene ether sulfone).

10. The display apparatus of claim 6, wherein the second protection film comprises one or more compounds selected from the group consisting of a silicon (Si) material, an acryl-based resin material, and an urethane-based resin material.

\* \* \* \* \*

|                |  |         |            |
|----------------|--|---------|------------|
| 专利名称(译)        | 柔性有机发光显示装置及其制造方法   |         |            |
| 公开(公告)号        | <a href="#">US10390389</a>   | 公开(公告)日 | 2019-08-20 |
| 申请号            | US16/140452  | 申请日     | 2018-09-24 |
| [标]申请(专利权)人(译) | 三星显示有限公司   |         |            |
| 申请(专利权)人(译)    | 三星DISPLAY CO. , LTD.   |         |            |
| 当前申请(专利权)人(译)  | 三星DISPLAY CO. , LTD.   |         |            |
| [标]发明人         | JUNG WOO SUK<br>PARK SOON RYONG<br>PARK HYE JUNG<br>BAEK SEOK GI<br>KIM TAE EUN      |         |            |
| 发明人            | JUNG, WOO-SUK<br>PARK, SOON-RYONG<br>PARK, HYE-JUNG<br>BAEK, SEOK-GI<br>KIM, TAE-EUN |         |            |
| IPC分类号         | H05B33/04 H01L51/52 H05B33/10  |         |            |
| CPC分类号         | H05B33/04 H05B33/10 H01L51/5256 H01L51/5253  |         |            |
| 优先权            | 1020120078958 2012-07-19 KR  |         |            |
| 其他公开文献         | US20190029085A1  |         |            |
| 外部链接           | <a href="#">Espacenet</a>  |         |            |

摘要(译)

在一个方面，一种柔性有机发光显示装置，包括基板;显示装置，形成在基板的第一表面上;覆盖显示装置的薄膜封装层;本发明提供一种通常围绕基板，显示装置和薄膜封装层的保护膜，以及制造柔性有机发光显示装置的方法。

